



# SMOKER CHS082E

Static oven with external  
smoking device

## CONSTRUCTION FEATURES

- Tightness chamber with radiused corners
- Total thermic insulation with rock or glass wool
- Long lasting frontal seals made up of food grade of high heat resistance
- Static heating provided by low consumption wire heating element that coils up all the chamber
- Snap-shut door
- Four swivel wheels of which 2 with brake
- All-around rubber bumpers
- Tightness cavity with radiused corners, built-in drip tray and drainage system

## FUNCTIONAL FEATURES

- Electronic control panel of temperature, time, core probe,  $\Delta t$  and smoking with LCD 4,3" touch-screen
- Operating temperature 30°C – 160°C
- End-of-cycle buzzer
- Chamber with safety thermostat
- Internal drain for easy cleaning
- Condensation drain tray
- Start timer programmed

## STANDARD SUPPLY

- Multipoint core probe with the possibility to register 30 different temperatures and save them in the HACCP report
- Glazed door plus lighting
- Removable GN 2/1 and GN 1/1 tray racks
- External stainless steel smoke generator with ash tray
- USB port saving device HACCP

## OPTIONS & ACCESSORIES

- |  |  |
|--|--|
| <input type="checkbox"/> EcoWash cleaning system | <input type="checkbox"/> Water filter system (together with washing)     |
| <input type="checkbox"/> Opposite side opening   | <input type="checkbox"/> Hooks kit                                       |
| <input type="checkbox"/> Grids                   | <input type="checkbox"/> Bag of wooden chips                             |
| <input type="checkbox"/> Trays                   | <input type="checkbox"/> Detergent/Rinsing agent (together with washing) |
| <input type="checkbox"/> UK plug                 |  |

### MODULINESRL



moduline

TECHNICAL  
INSTALLATION  
DIAGRAM

Electricity supply  
cable inlet

Smoke exhaustion  
vent

Chamber drain  
and condensation  
drain tray

Condensed discharge

**Important** - Drawing and  
dimensions refer to the  
standard version.  
They may change with the  
addition of accessories or  
options.

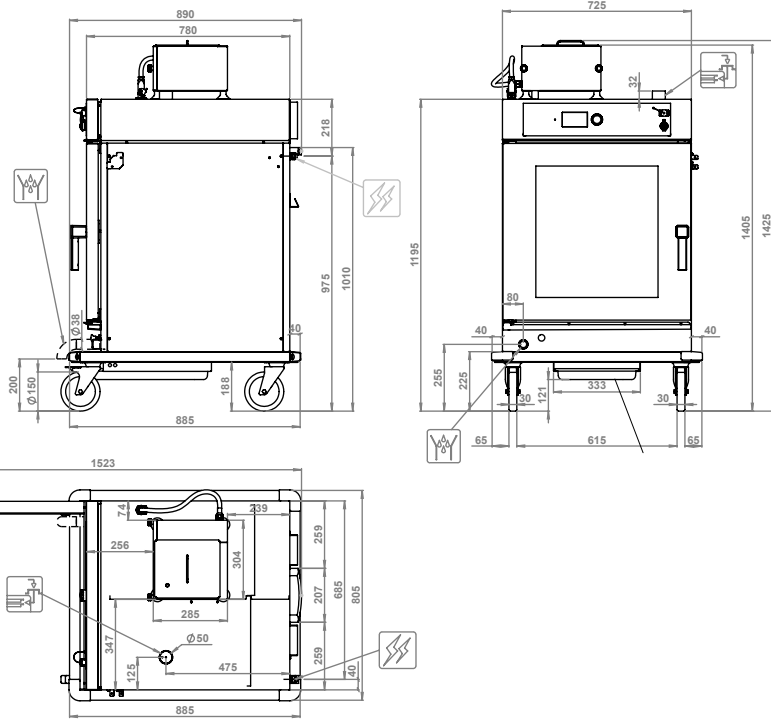

Overall dimensions  
(W x D x H) - mm 805 x 890 x 1425h

Power supply AC 220-240V 50/60Hz

Total input  
[kW] 2,95 (230V) same consumption with Ecowash

Amps.  
[A] 12,9 (230V) same consumption with Ecowash

Working temperature  
[°C] 30 + 160

Trays capacity -  
distance [mm] 8 x GN 2/1 - (75)  
16 x GN 1/1 - (75)

Product max capacity  
[Kg] 55

Net weight  
[Kg] 107

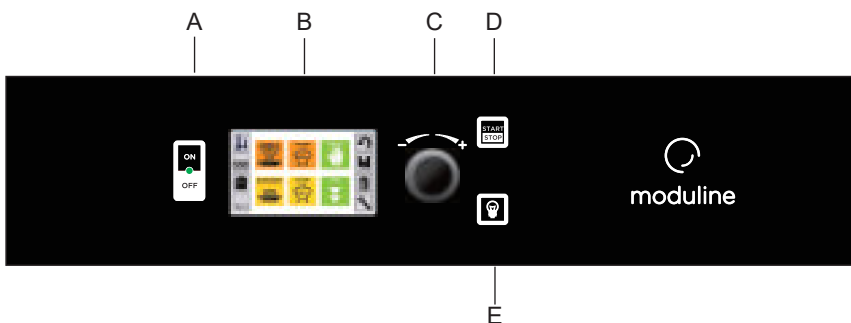

- A ON/OFF switch
- B Display Touch Screen
- C Setting knob  
and select "ENTER"
- D "START/STOP" button
- E Chamber light button

MODULINESRL

Via dell'Industria 11, Z.I. San Giacomo di Veglia 31029 Vittorio Veneto (TV) - ITALY  
tel. +39 0438 5063 - fax +39 0438 912 323 - info@moduline.it - www.moduline.it